



Smartlink™ Vantage (SL-Vantage) Operations Manual Version 3.0

Table of Contents

Revision History	2
Outdoorlink® - Smartlink Vantage Introduction	3
Safety and Installation	4
Safety Alert	4
Installation & Activation	4
Features and Functions	5
Notifications & Alarms	6
Interfaces	7
Block Diagram	8
Cellular Connection	9
Dimensions	10
Wiring Diagram	11
Parts List	12
Pre-Installation Assessment	17
Installation Process	18
Pre-Install	18
Positioning and Mounting the Smartlink Vantage Controller (Exhibit 1)	19
Connecting Video Cables to the Smartlink Vantage Controller (Exhibit 2)	19
Connecting Power Cables to the Smartlink Vantage Controller (Exhibit 2)	20
Installing Flex Circuit & Sensor + Sensor Housing (Exhibit 3)	21
Finalize Installation & Activate Unit	22
Auto-Calibration	23
Exhibit 1	25
Exhibit 2	27
Exhibit 3	29
Specification Summary	31

Revision History

Version	Date	Author	Summary
0.0		C. Weiland	Initial Release
1.0	7/16/21	C. Weiland	Updated for Injection Molded Vantage Case
2.0	7/28/21	C. Weiland	Auto-Calibration details included, Cellular Connection, LED Indicators
3.0	12/4/21	C. Weiland	Included antenna mode toggle instructions

Outdoorlink® - Smartlink Vantage Introduction

Smartlink Vantage technology is a cloud-based application that communicates over a secure cellular network to provide centralized management, remote control, and verification of digital video devices. The technology combines remote device management with advanced uptime verification. A single controller can independently manage (2) separate DC-powered devices in addition to a digital display. This allows for rebooting, scheduling, power monitoring and more.

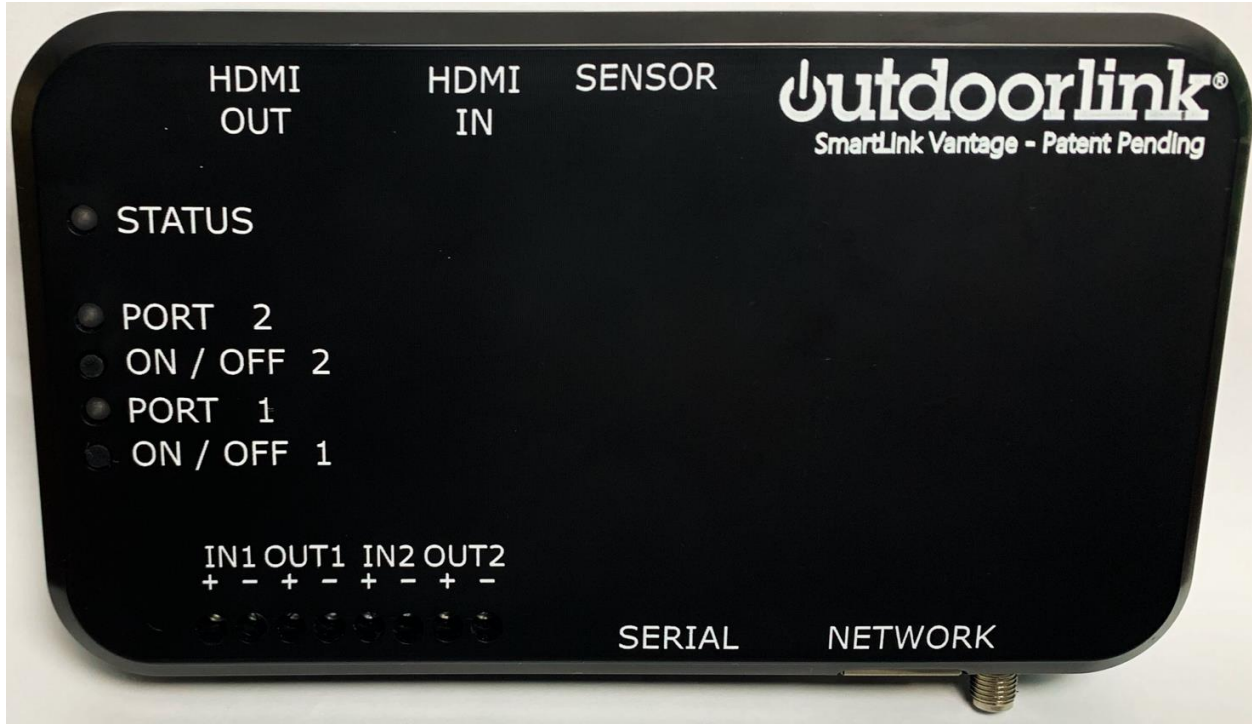

Outdoorlink offers 24/7 technical support via phone or email from its Huntsville-based support team to ensure issues are resolved as soon as possible. Please call (256) 885-9768 or email support@Outdoorlinkinc.com to reach a support representative.

Safety and Installation

Safety Alert

Caution must be taken while installing the Smartlink Vantage unit. Personal Protective Equipment (PPE) must be worn as applicable. Do not touch any area of the exposed circuit board or uninsulated wires/connections while the device is energized.



Verify power is turned off before working with the unit!



Please consult this manual for additional information on the Smartlink Vantage. For questions or concerns call technical support at (256) 885-9768 or email support@Outdoorlinkinc.com.

Installation & Activation

Please read the following instructions prior to installation

1. Please refer to the instructions, specifications and wiring diagrams in this manual. Contact customer support if there are any installation questions. Outdoorlink, Inc. recommends that all applicable electrical codes be observed while installing and troubleshooting the units. Please note that electrical codes vary by area. Consult local electrical codes prior to installation.
2. **Once the controller is installed, contact Outdoorlink customer support at (256) 885-9768 to activate your unit and to ensure the system is operating properly. The device will not operate until this step is complete.**

Please have the following details known or readily available:

- a. Name & location that the controller is installed
 - b. GPS Coordinates (if applicable)
 - c. Devices (type, model) connected to the Smartlink Vantage
 - d. Desired scheduling (device on/off & day of week)
 - e. ICCID – Numeric identifier is labeled on the enclosure. Ex. 89014103271407802097
3. If not yet completed, customer support will create a user web account to access the Portal. Portal training will be provided by an Outdoorlink representative when requested. A Portal user manual is also available for a complete review of the system.
 4. Once the Smartlink Vantage unit is powered up and customer support has activated the device, please log in to the Portal at <https://portal.Outdoorlinkinc.com/login> using the provided credentials to begin remotely managing devices!

Features and Functions

The Smartlink™ Vantage is an integrated solution excelling at both remote device management and true proof of performance verification for digital advertising systems. The combination of advanced video processing capabilities, optical-sensing hardware and intelligent algorithms confirms overall system health. Its cloud-based management system can reboot separate hardware components remotely from a computer or mobile device and send real-time alert notifications to resolve issues as soon as possible.

Smartlink Vantage Specifications

Device Management	Manage (2) separate devices: Digital displays, routers/modems, media players and more
Enclosure	Polycarbonate, 3 x 6 x 0.75 in. (approx. 15.2 x 7.6 x 2.0 cm), Weight: 6 ounces
Input Power	Two independent inputs, 8-28V @ 4A
Output Power	Two independent outputs, 8-28V @ 4A
Temperature & Environmental	0°C to 50°C, 0-95% humidity, non-condensing, RoHS
Wiring Connection	Terminal Block (18 AWG wire), specific connector types available upon request
Connectivity	LTE CAT M1 cellular with internal SIM, internal and optional external antenna connection
Display Resolution	Single screen - 1920 x 1080p @ 60 fps
Hardware Interfaces	HDMI (x2 – video input, output), terminal block, Micro-USB, GigE Ethernet, sensor port
System Reporting	Power readings, proof of performance, alarm history, screen image capture, frozen screen
Alarm Notifications	Loss of power, no display detected, no video input, no content on screen

Notifications & Alarms

Smartlink Vantage provides (12) different real-time alarm notifications to alert users of power issues and video system errors. Common video system errors include player locked up, displayed error message, wrong input, screen off and internet outages. A significant majority of these error scenarios presented below, are immediately detected by Smartlink Vantage.

Power Management

1. Loss of Incoming Power – Loss of input power supply
2. No Device Power 1,2 – Devices connected to Smartlink Vantage are not powered on

Video System Integrity

1. No Display Detected – Screen failure, screen off/unplugged, video cable disconnected
2. No Video Input – Media player off, player failure, player locked up
3. No Video Output – Screen failure, wrong video input channel, display issue

Image Analysis

1. Static Screen – Frozen screen, ad rotation not playing properly

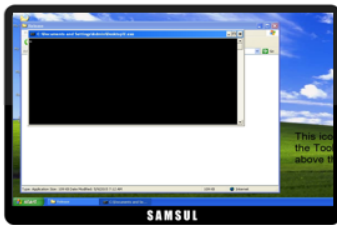

Pop-Up/Dialog Box

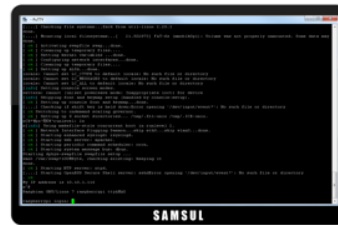

No Video Output

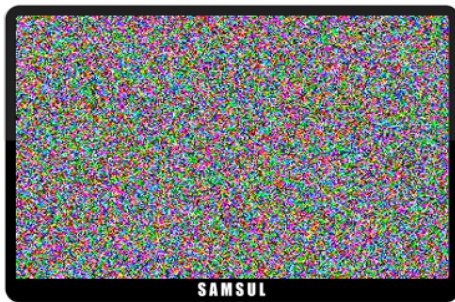

No Input

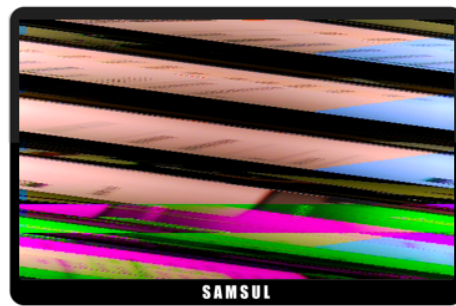

Screen Failure/Distorted Content



Interfaces

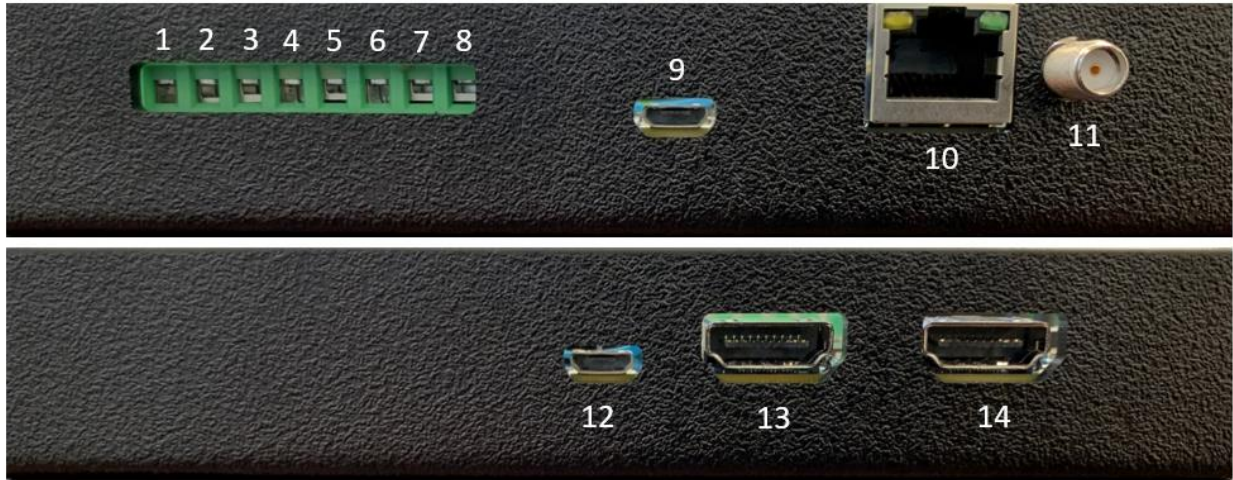

Interface List	
1	Terminal Block IN1 (+)
2	Terminal Block IN1 (-)
3	Terminal Block OUT1 (+)
4	Terminal Block OUT1 (-)
5	Terminal Block IN2 (+)
6	Terminal Block IN2 (-)
7	Terminal Block OUT2 (+)
8	Terminal Block OUT2 (-)
9	USB 2.0 Micro-B Female
10	RJ45 GigE to Serial Female
11	Antenna Port Internal Antenna – Standard External Antenna - Optional
12	USB 2.0 Micro-B Female - Sensor Port
13	Video In – HDMI Type A Female
14	Video Out – HDMI Type A Female

Block Diagram

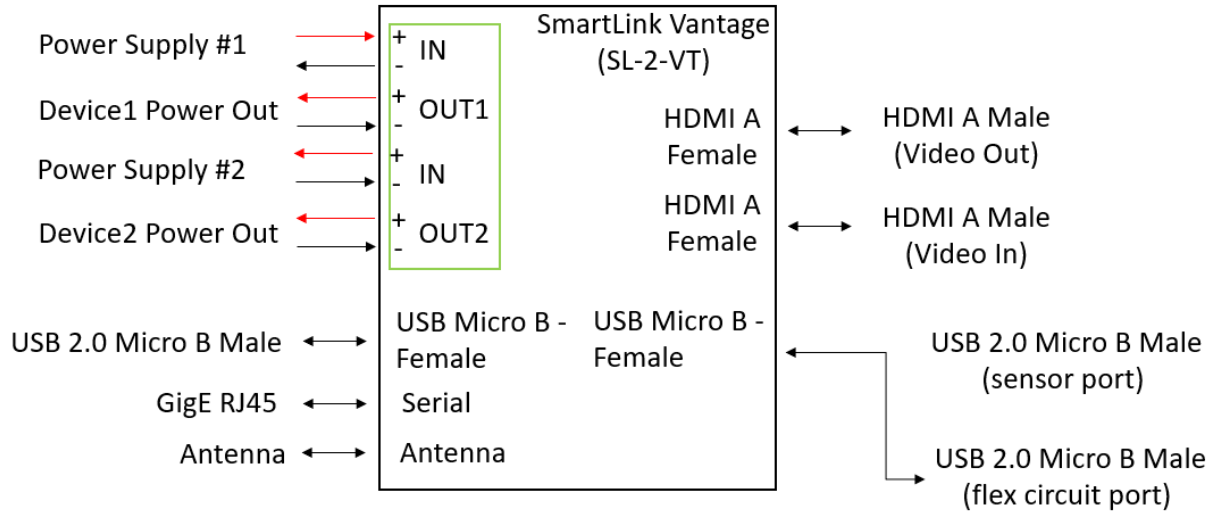

Cellular Connection

Smartlink Vantage includes an integrated cellular modem to enable communication between the device and Outdoorlink's servers. Smartlink Vantage uses LTE CAT M1 cellular technology which is designed for IoT devices. Smartlink Vantage has two antenna modes – internal and external – and is configured to internal mode when shipped.

It is critical that the Smartlink Vantage is configured for the proper antenna mode. A user may change antenna mode by pressing the "ON/OFF 2" or "ON/OFF 1" push buttons for 5 seconds. The Status LED provides visual confirmation of what antenna mode the Smartlink Vantage is set to.

Installation Tips:

- Avoid placing the Smartlink Vantage in enclosed spaces unless necessary. An external antenna is recommended when the device must be placed in an enclosed area such as a hardware cabinet.
- When mounting external antennas, orientation and plane are important factors to consider. Verify with Outdoorlink on the ideal mounting position.
- Place the Smartlink Vantage with as much free space as possible from other electronic devices.

Status LED

- Slow Blink: One blink per second continuously indicates that the device is searching for the cellular network while in **internal** antenna mode.
- Slow Blink with Two Second Pause: One blink per second for two seconds followed by two second pause indicates that the device is searching for the cellular network while in **external** antenna mode.
- Rapid Blink: Multiple blinks per second confirms the device is connected to the cellular network **AND** configured for **internal** antenna mode.
- Rapid Blink with One Second Pause: Rapid blink for five seconds followed by a one second pause confirms that the device is connected to the cellular network **AND** configured for **external** antenna mode.

Port 1,2 LED

- A solid LED indicates Port 1,2 is powered with a load connected.
- A rapid blink LED light Port 1,2 is powered without a load connected.
- No LED indicates Port 1,2 is not powered.

On/Off 1,2

- Push button to toggle Port 1,2 to ON or OFF position.



Dimensions

Smartlink Vantage Size & Weight Details	
Material	3mm PC/ABS
Color	Black
Finish	Slight Texture
Weight	6.1 oz.
Length	5.8 in.
Width	3.277 in.
Height	1.103 in.

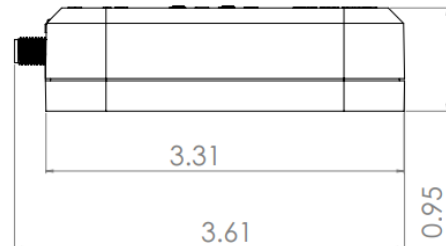
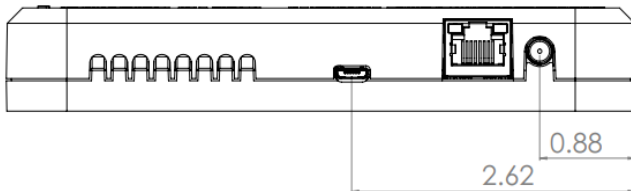
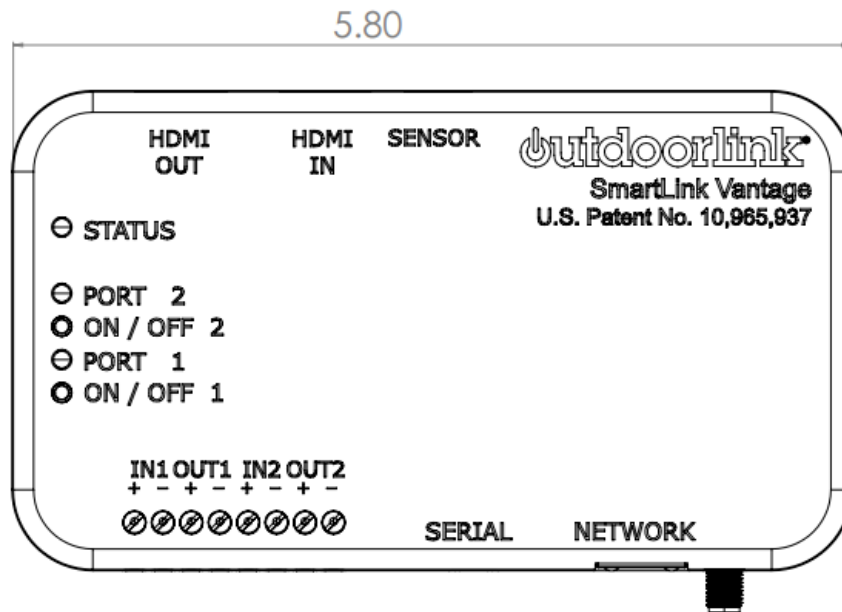

Wiring Diagram

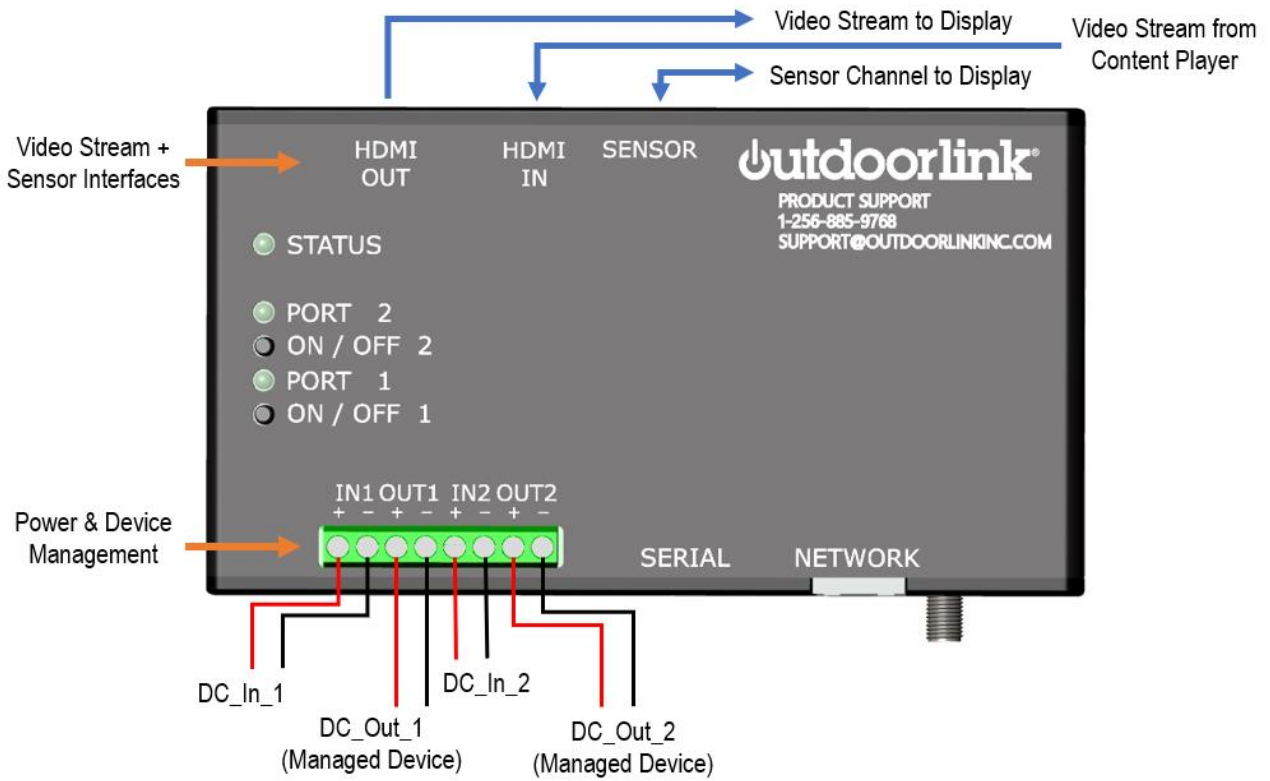

Parts List



Smartlink Vantage Main Controller



Cable Assembly – Barrel – Power Cables

Integral Unit – Jack to Plug

Standard Sizes (6 ft. length):

1. 1.35 mm ID, 3.5 mm OD
2. 2.1 mm ID, 5.5 mm OD
3. 2.5 mm ID, 5.5 mm OD



Cable Assembly – Barrel – Power Cables

Jack x Wire Leads

Standard Sizes (3 ft. length):

4. 1.35 mm ID, 3.5 mm OD
5. 2.1 mm ID, 5.5 mm OD
6. 2.5 mm ID, 5.5 mm OD



Cable Assembly – Barrel – Power Cables

Plug x Wire Leads

Standard Sizes (3 ft. length):

- 7. 1.35 mm ID, 3.5 mm OD
- 8. 2.1 mm ID, 5.5 mm OD
- 9. 2.5 mm ID, 5.5 mm OD



Sensor Housing – ABS Black Plastic

Visible Housing Size – 1 cm x 1 cm



Flexible Circuit Assembly - Sensor

Length – 15.3 cm (6 in.)

Sensor – 0.6 cm x 0.6 cm (mounts inside housing)

Connection – Micro USB B Female



Sensor Cable Assembly
Micro USB B male to Micro USB B male
Standard Length – 1 meter



Power Supply – AC to DC Converter



Video Cable Connection
HDMI Type A – Male x Male
Length – 1 meter



Mounting Strips – Heavy Duty Velcro
Pad Size - 4 in. x 2 in



Assorted Zip Ties
Sizes: 4" & 8"



Adhesive Cable Tie Mounts
Size: 1 in. x 1 in.



Assorted Cable Adapters
Common Video Connections x HDMI Type A



Adhesives:
Clear Plastic Glue
Clear Double-Sided Tape



External Antenna (Optional)
LTE Antenna Support LTE CATM1 Bands

Pre-Installation Assessment

Perform a pre-installation assessment prior to the start of the installation. The assessment serves to identify important details and considerations to ensure an efficient setup.

Power Source

- a. Location of power supply
- b. Distance from power source to hardware devices
- c. Distance from display
- d. Power source type (wall outlet, power strip, other)

Hardware Device #1 – Content Player

- a. Location of content player
- b. Manufacturer/model
- c. Presence of AC/DC converter
- d. Power requirements and cable size
 - a. 1.35 x 3.5 mm, 1.7 x 4.75 mm, 2.1 x 5.5 mm, 2.5 x 5.5 mm, other
- e. Distance from content player to display
- f. Number of screens receiving content from player

Hardware Device #2 – Router/Modem, Other

- a. Location of device
- b. Manufacturer/model
- c. Presence of AC/DC converter
- d. Power requirements and cable size
- e. 1.35 x 3.5 mm, 1.7 x 4.75 mm, 2.1 x 5.5 mm, 2.5 x 5.5 mm, other
- f. Distance from device to content player
- g. Distance from device to display

Display

- a. Manufacturer/Model
- b. Video input connections (HDMI, DP, DVI, VGA, etc.)
- c. Primary input # (1,2,3,4, etc. - input used to play advertisements)
- d. Determine A – E measurements

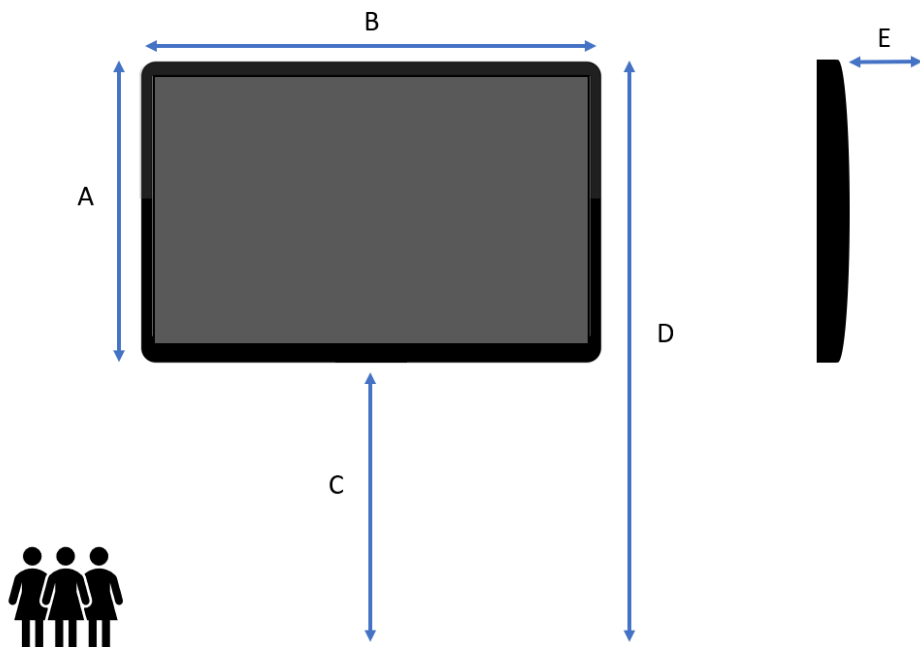

Installation Process

Pre-Install

1. Complete the pre-installation assessment and verify all required parts and tools are available to complete the work scope.
2. Conduct a pre-job safety analysis to identify hazards and the appropriate risk prevention/mitigation procedures to perform the work safely.
3. It is beneficial to visualize the end-product installation before starting the process. Below is an example installation for reference. Individual installations will vary based on location and equipment specifics, but the process flow for the Power and Video circuits remains the same.

Power – Power Supply > Smartlink Vantage In 1,2 – Smartlink Vantage Out 1,2 > Device 1,2
 Video – Content Player Out > Smartlink Vantage In – Smartlink Vantage Out > Display

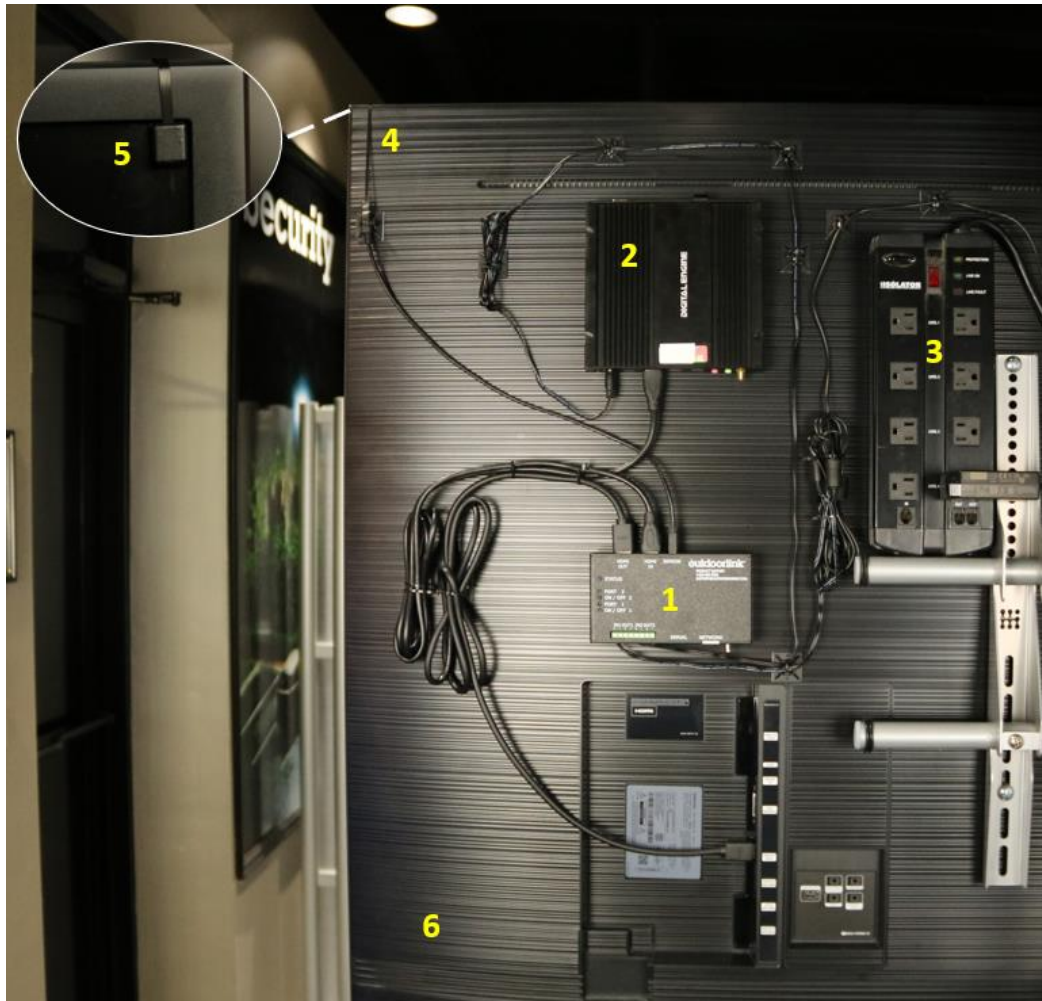

Call Outs:

- | | | |
|---------------------------------|----------------------------|--------------------|
| 1) Smartlink Vantage Controller | 2) Content Player | 3) Power Supply |
| 4) Flex Circuit | 5) Sensor + Sensor Housing | 6) Digital Display |

Positioning and Mounting the Smartlink Vantage Controller (Exhibit 1)

1. Reference Exhibit 1. Disconnect power to the digital display and hardware devices that will be remotely managed by the Smartlink Vantage controller.
2. Identify the position and orientation of the content player in relation to the display. Identify the position of the power source and power cables used by the hardware devices. Consider the optimal mounting position.
Do not mount at this point.
3. The Smartlink Vantage controller should be installed within 3 ft. (1 meter) of the sensor + sensor housing assembly. Identify which corner of the display will be monitored with the sensor + sensor housing assembly.
4. Proceed to mount the Smartlink Vantage using the Velcro strips or other preferred method.
5. The Smartlink Vantage controller is now installed. Proceed to the next section for instructions on connecting the devices to power and video.

Connecting Video Cables to the Smartlink Vantage Controller (Exhibit 2)

1. Reference Exhibit 2. Locate the content player video out port and cable.
2. In some cases, a content player will have multiple videos out ports and cables.
3. Ensure the correct video output and cable is used.
4. Insert the video cable into the “HDMI IN” port on the Smartlink Vantage controller.
5. Locate the video input ports on the display.
6. Displays typically have multiple inputs of different types including HDMI, DVI, DisplayPort, VGA and others. Verify and record what the primary input is for the display.
7. Record both type and number (e.g. HDMI Input #1).

A video cable adapter to HDMI Type A may be required. Required video cable adapters x HDMI Type A are identified during the pre-assessment step.

8. Connect the video cable between the “HDMI Out” on the Smartlink Vantage controller and the primary input on the display.
9. Use the zip ties and adhesive cable mounts to secure the video cables.

Connecting Power Cables to the Smartlink Vantage Controller (Exhibit 2)

1. Reference Exhibit 2. Locate the power source, hardware devices to be managed and AC-DC converters. The pre-installation assessment determined the power requirements of the devices and cable connector size.
2. Select the appropriate power barrel connectors that match the AC-DC converter plug and hardware device jack. For clarity in terminology, an image of a plug and jack connection is provided. The plug is normally at the end connection of the AC-DC converter while the jack is located on the hardware device.



3. Insert the wire leads to Plug or Jack connection into the Smartlink Vantage controller terminal block by loosening each screw, inserting the wire and tightening the screw to secure the wire in place. Ensure that the correct polarity is observed by inserting the positive wire into the positive terminal and the negative wire secured in the negative terminal.
4. Insert the plug into the jack to make up barrel connectors.
5. Use the zip ties and adhesive cable mounts to secure the power cables.

Installing Flex Circuit & Sensor + Sensor Housing (Exhibit 3)

1. Reference Exhibit 3. Determine the corner of the display to install the flex circuit and sensor + sensor housing. Identify which mounting tab will be used. Remove the unused mounting tab using a file or scissors.

Note: The Smartlink Vantage controller should be installed within 3 ft. (1 meter) of the sensor + sensor housing assembly.

2. Prepare to bond the flex circuit + sensor inside the sensor housing. Apply a small piece of double-sided tape on the internal chamber of the sensor housing. Insert the flex circuit into the sensor housing while **ensuring the sensor side faces upwards**. The adhesive must be applied to the backside of the flex circuit so that the sensor can monitor the screen without obstruction.
3. Mount the sensor housing to the display. Gently slide the tabs beneath the bezel of the display. Orient the sensor housing so that the flex circuit wraps around the display in the ideal position (over top, around side, etc.).

Specialty 3M VHB clear, double-sided adhesive tape is provided for displays that 1) do not have a bezel or 2) have a bezel, but do not allow for a press fit installation. For this scenario, first adhere the tape to the sensor housing. Then adhere the sensor housing the display.

4. Insert the sensor cable (micro-USB B male x male) into the “Sensor” interface on the Smartlink Vantage controller. Connect the remaining end to the micro-USB B female connection on the flex circuit.
5. Use the zip ties and adhesive cable mounts to secure the flex circuit and sensor cable connection.

Finalize Installation

1. Verify that the system is cabled correctly by tracing the power and video cables.
2. Ensure that the cabling, components, and flex circuit + sensor housing are secure in place. Use additional zip ties and cable adhesive mounts where necessary.
3. Restore power to the digital display and hardware devices.
4. Verify that the Smartlink Vantage controller LED “Status” is blinking. Refer to the details in the “Cellular Connection” section of this document.
5. Contact Outdoorlink customer support at (256) 885-9768 to activate your unit and to ensure the system is operating properly. The device will not operate until this step is complete.

The following details are required:

- f. Name & location that the controller is installed
 - g. GPS Coordinates (if applicable)
 - h. Devices (type, model) connected to the Smartlink Vantage
 - i. Desired scheduling (device on/off & day of week)
 - j. ICCID – Numeric identifier is labeled on the enclosure. Ex. 89014103271407802097
6. If not yet completed, customer support will create a user web account to access the Portal. Portal training will be provided by an Outdoorlink representative when requested. A Portal user manual is also available for a complete review of the system.
 7. Once the Smartlink Vantage unit is powered up and customer support has activated the device, please log in to the Portal at <https://portal.Outdoorlinkinc.com/login> using the provided credentials to begin remotely managing devices. Follow calibration instructions below for accurate monitoring.

Auto-Calibration

After installation and activation, calibration is necessary to ensure accurate sensor readings. Smartlink Vantage allows for calibration feature that performs the necessary calibration routine and saves the parameters automatically.

1. Press and hold both Port 1 & Port 2 push buttons for 10 seconds. This causes the device to enter calibration mode.

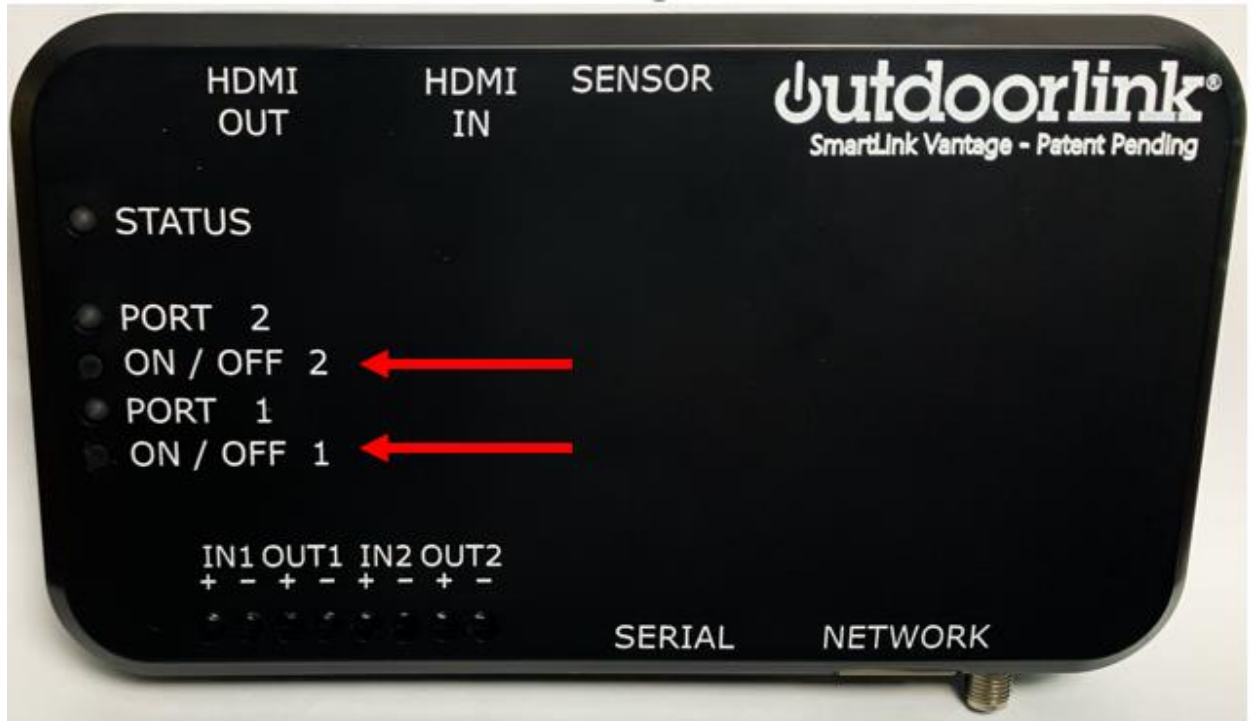

2. A green square will cycle through each corner of the LCD screen for approximately 4 seconds to locate which corner the sensor is installed. The green square will then locate and remain where the sensor is installed.



3. Use the Port 2 push button to size the green square appropriately. Press and Release Port 2 button until the green square is just hidden beneath the sensor housing. The green square should not be visible when standing in a normal viewing position in front of the screen.
4. Use the Port 1 push button to save the sensor location, size. This information and calibration set points will be automatically sent to the server and saved.
8. The Smartlink Vantage will automatically exit the calibration routine and resume playing the media content. Log in to the Portal at <https://portal.Outdoorlinkinc.com/login> using the provided credentials to begin remotely managing devices!

Exhibit 1



1. Smartlink Vantage Controller – Positioned based on access to power, video and sensor circuits.
2. Content Player
3. Power Supply
4. Flex Circuit
5. Sensor + Sensor Housing
6. Digital Display



1. Side views of installation for reference.

Exhibit 2



1. HDMI Out – Video Signal from Smartlink Vantage Controller to LCD Display
2. HDMI In – Video Signal from Content Player to Smartlink Vantage Controller
3. Sensor Input – Sensor Signal from Optical Sensor to Smartlink Vantage Controller
4. Power Supply In – Power Source to Smartlink Vantage Controller Power Input
5. Power Supply Out – Smartlink Vantage Controller Power Output to Device (Content Player)
6. Barrel Power Connectors – Quick Connects

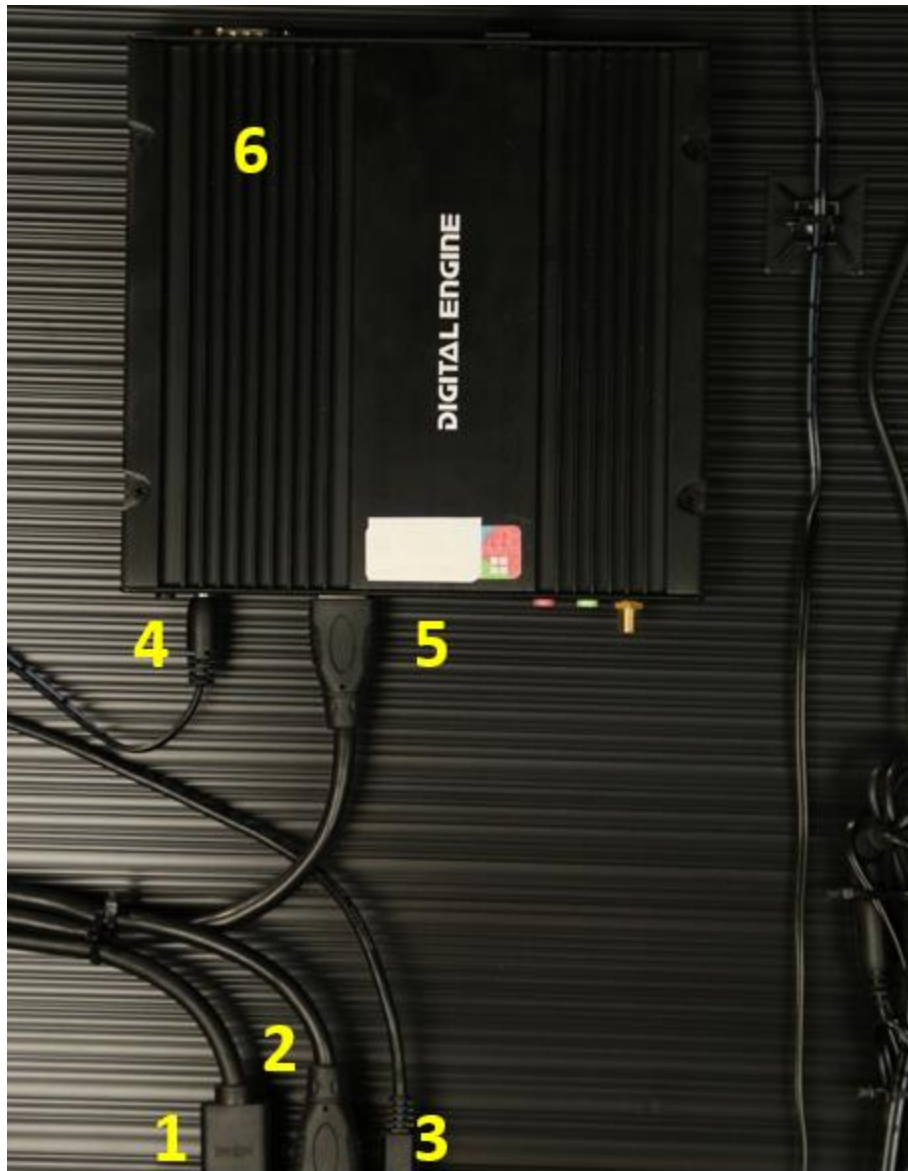

1. HDMI Out – Video Signal from Smartlink Vantage Controller to LCD Display
2. *HDMI In – Video Signal from Content Player to Smartlink Vantage Controller
3. Sensor Input – Sensor Signal from Optical Sensor to Smartlink Vantage Controller
4. Power Connector– Smartlink Vantage Controller Power Output to Device (Content Player)
5. *Video Signal from Content Player to Smartlink Vantage Controller
6. Content Player

*Note – Connector 2 & 5 belong to the same HDMI cable.

Exhibit 3





1. Flex Circuit Connector to Sensor Cable. Sensor Cable connects to Smartlink Vantage Controller at “Sensor” interface. This port is labeled on the enclosure.
2. Flex Circuit with Micro USB B Female connector exposed.
3. Sensor Cable with Micro USB B Male connector exposed.

Specification Summary

1. Measurement Capability
 - a. Input Voltage/Battery Voltage (supply)
 - b. Output Current (per port)
2. Multiple Device Management
 - a. Ability to remotely manage up to two devices per controller.
3. Rebooting
 - a. Reboot devices individually from any desktop or mobile device.
 - b. Verification of restored power after a device has been rebooted.
4. Connectivity
 - a. LTE CAT M1 cellular connection with internal SIM and integrated antenna with external antenna option.
 - b. Utilizes an independent cellular connection. Does not require dependence on a cellular connection of another device's board.
5. Scheduling
 - a. Run-time settings defined automatically with GPS based sunrise/sunset times and/or manual time scheduling.
 - b. Internal real-time clock provides automatic and accurate daylight savings adjustments.
 - c. Schedule up to two devices independently.
 - d. Day-of-week scheduling capabilities per output.
 - e. Up to four schedules per output.
6. System Notifications
 - a. Users notified in real-time via email of system alarms:
 - i. Power – Loss of power, offline and connected device – no power
 - ii. Video System Integrity – Display, video input, video output error
 - iii. Image Analysis – Image error detection and analysis capability
7. Power Management
 - a. Input power: 8 to 28Vdc @ 4A
 - b. Output power: 8 to 28Vdc @ 4A per port.
8. Environmental
 - a. 0-95% humidity, non-condensing, RoHS.
 - b. Operating/Storage Temperature: -0°C to 50°C
9. Installation
 - a. 18 AWG terminal block connections.
 - b. 24/7 on-call technical support.
10. Software
 - a. Cloud based access from any desktop or mobile device with iOS and Android mobile compatibility.
 - b. Hosted by a secure cloud-based Amazon Web Service (AWS).
 - c. Open API for integration into third-party content management or CAD-AVL systems.
 - d. Provides reports and charting of Power Readings, Proof of Performance, Command Logs, Maintenance Logs and Alarm History.